

THIS DRAWING IS UNPUBLISHED. RELEASED FOR PUBLICATION ,19 .  
 © COPYRIGHT 19 BY AMP INCORPORATED. ALL RIGHTS RESERVED.

LOC		DIST		REVISIONS			
P	LTR	DESCRIPTION		DATE	DWN	APVD	
AF	50	E		REV PER 0G3A-0113-02	01MAR02	JR	PD

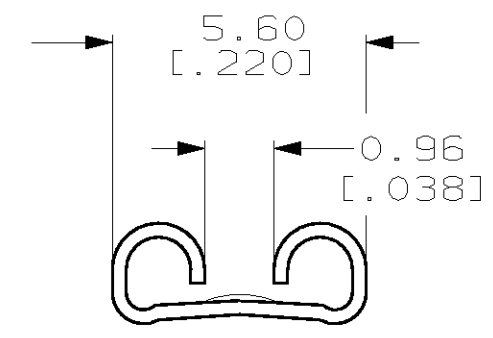
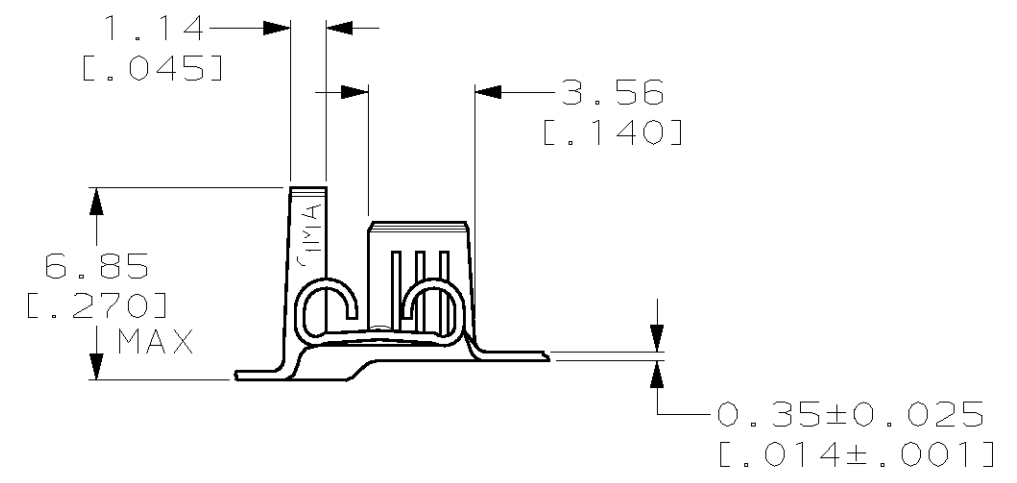
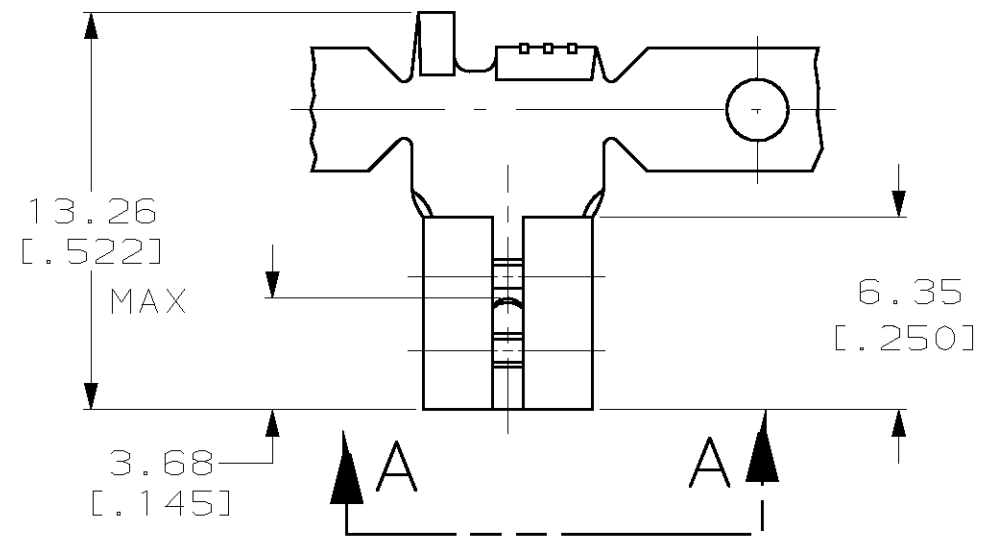

VIEW A-A  
SCALE 6:1

- 1 CONTINUOUS STRIP ON REELS.
- 2 FEED IS 16.51±0.076 [.650±.005].
- 3 ACCEPTS WIRE SIZE [#20-#16] AWG.
- 4 INSULATION RANGE TO BE 2.29-3.30 [.090-.130] DIA.
- 5 MATING TAB THK TO BE 0.406±0.025 [.020±.001].

0.002032 [.000080] MIN TIN	1217009-2
-	1217009-1
FINISH	PART NO.

THIS DRAWING IS A CONTROLLED DOCUMENT FOR AMP INCORPORATED. IT IS SUBJECT TO CHANGE AND THE CONTROLLING ENGINEERING ORGANIZATION SHOULD BE CONTACTED FOR THE LATEST REVISION.		DWN JR RUTH 8/22/97	<b>AMP</b> AMP Incorporated Harrisburg, PA 17105-3608
DIMENSIONS: MM [INCHES]		CHK MS FEHER 8/22/97	
TOLERANCES UNLESS OTHERWISE SPECIFIED: 0 PLC ±- 1 PLC ±- 2 PLC ±0.25 [.010] 3 PLC ±- 4 PLC ±- ANGLES ±-		APVD P DESANTIS 8/22/97	NAME RECEPTACLE, FASTON, FLAG, 4.75 [.187] SERIES
MATERIAL H04 BRASS		PRODUCT SPEC -	SIZE A3
FINISH SEE TABLE		APPLICATION SPEC 114-2155	CAGE CODE 00779
		WEIGHT -	DRAWING NO C-1217009
		CUSTOMER DRAWING	SCALE 4:1 SHEET 1 OF 1 REV E